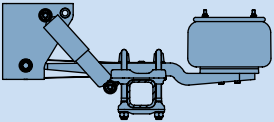
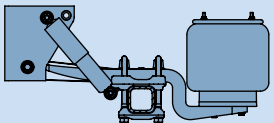
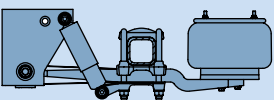

BPW SL air suspension.

SLO, SLM and SLU series.

Axle loads 9,000 kg to 12,000 kg.

Air-sprung axles and axle units	Trailing arm 100 mm	Bracket ¹⁾ (ST) (mm)	Axle type Drum brake ²⁾	Air bag	Ride height (FH) (mm)	Axle type Disc brake ³⁾	Air bag	Ride height (FH) (mm)
SLO series								
	Single-leaf 1 x 57	268 370	HSF ⁷⁾ HZF ⁷⁾ HS...LL HZ...LL	36/36 K	400-600 LL 410-600	S(K)HSF... S(K)HZF... S(K)HSFH...LL ⁸⁾ SKHZFH...LL ⁸⁾	36/36 K	400-600 LL 410-600
	Double-leaf 2 x 43				420-610 LL 430-610			420-610 LL 410-600
Double-sided lift				•			•	
Lateral axle lift				• ⁵⁾			-	
Central axle lift				•			•	
SLM series								
	Single-leaf 1 x 57	184 268	HSF ⁷⁾ HZF ⁷⁾ HS...LL HZ...LL	36/36 K	305-500 LL 315-500	SHSF... SHZF... S(K)HSF...LL ⁸⁾ SKHZH...LL ⁸⁾	36/36 K	305-500 LL 340-470
	Double-leaf 2 x 43				330-500 LL 340-500			330-500 LL 340-470
Lateral axle lift				• ⁵⁾			-	
Central axle lift				•			•	
SLU series								
	Single-leaf 1 x 57	268 302 370	HSF ⁷⁾ HZF ⁷⁾ KHZF NHZF HS...LL ⁶⁾ KHS...LL ⁶⁾	36/36 K 36-1	210-360 LL 225-350	SKHZF... ⁹⁾ S(K)HBF...LL ⁸⁾	36/36-1	210-370 LL 240-340
	Double-leaf 2 x 43							250-370
	Single-leaf 1 x 58* (long-travel 620 / 365)	184 268	KHSF KHZF NHZF	36-1	185-350	SKHZF... SKHBF... S(K)HBF...LL ⁸⁾	36-1	220-350 LL 230-350
	Double-leaf 2 x 51* (long-travel 690 / 310)	268		36-1	235-345			SKHZF... SKHBF...
Lateral axle lift				• ⁵⁾			• ⁵⁾	
Central axle lift				•			•	

*Only for 9 t axle loads.
Additional types available on request.

SLO single-leaf

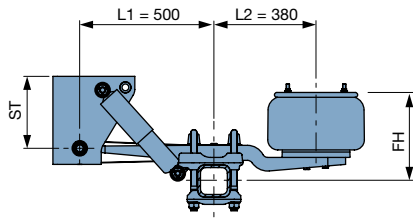

SLU single-leaf

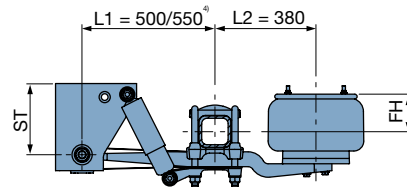

SLO double-leaf

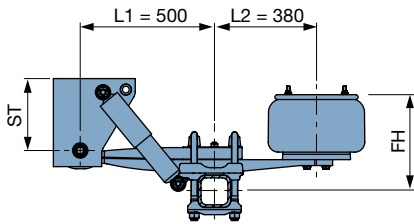

SLU double-leaf

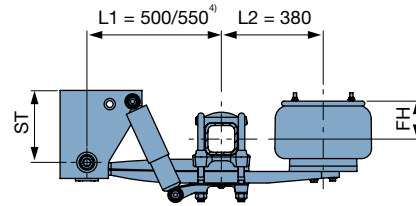

SLM single-leaf

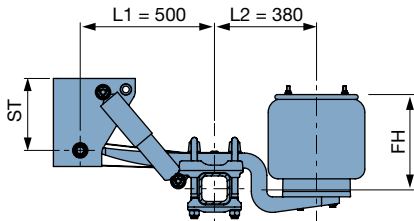

SLU single-leaf, long-travel

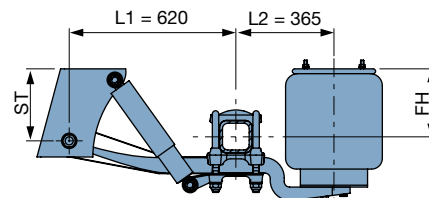

SLM double-leaf

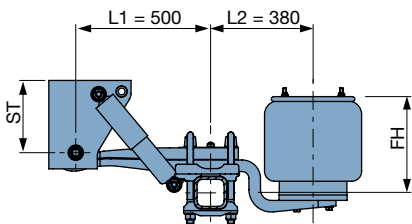

SLU double-leaf, long-travel

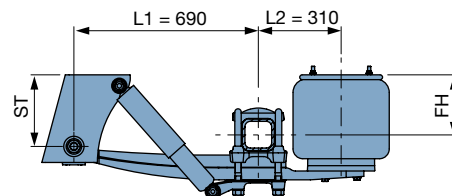

¹⁾ In standard or HD versions.

²⁾ NHZF - SN 300, AK 120 x 15, axle load 9 t - 11 t.

KHSF/KHZF - SN 360, AK 120 x 15, axle load 9 t - 11 t.

HSF/HZF - SN 420, AK 120 x 15/150 x 16, axle load 9 t - 12 t.

³⁾ SKHSF/SKHZF - TSB 3709, AK 120 x 15, axle load 9 t - 10 t.

SKHB - TSB 3709, AK 120 x 15, axle load 9 t.

SHSF/SHZF - TSB 4309, AK 120 x 15, axle load 9 t - 10 t.

SHBF - TSB 4309, AK 120 x 15, axle load 9 t.

SHSF/SHZF - TSB 4312, AK 150 x 16, axle load 11 t - 12 t.

LL with TSB 3709 or 4309 only up to max. 10t axle load or with SLU only up to max. 9t axle load, only 120 offset and single tyres.

⁴⁾ 550 with disc brake.

⁵⁾ Only with 1st suspension axle.

⁶⁾ FM min. 980 mm.

⁷⁾ Up to 9 t AK 120 mm, 10 t up to 12 t AK 150 mm.

⁸⁾ Only AK 120 mm □ or ■.

⁹⁾ L1 = 550, spring 1x 54, max. 10 t.

More information:

► SL air suspension (page 47) ► Recommended applications (page 48)

BPW air suspension hanger bracket and channel crossmember. SL versions.

BPW SL air suspension hanger bracket (100 mm wide trailing arm)

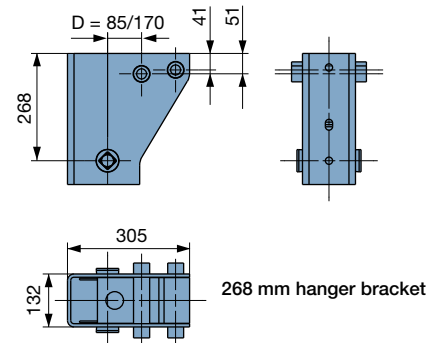
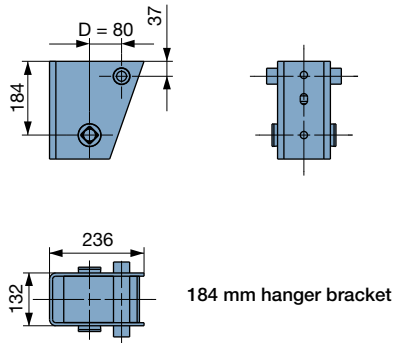

BPW SL channel crossmember

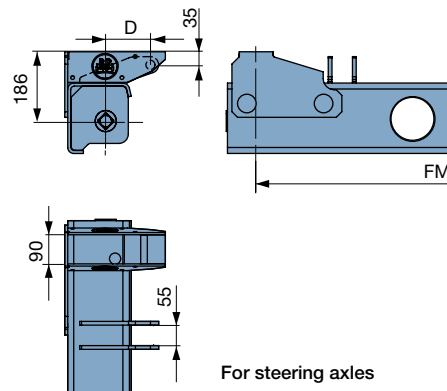
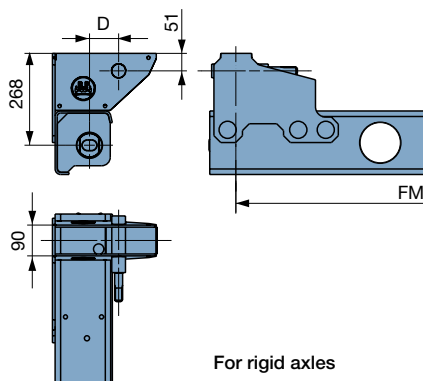

Other versions and details are available on request.



BPW SL air suspension hanger brackets – Features and benefits

- ▶ Hanger bracket height 184, 268, 302 or 370 mm
- ▶ With integrated track setting as option
- ▶ Optionally available with top plate (version D)
- ▶ Optionally available in heavy-duty version (version HD)
- ▶ Optionally available as narrow hanger bracket (version S)