

THE NETHERLANDS
(N E D E R L A N D)**ECE R13-11, Annex 11 – Appendix 3**
Test report form as prescribed in Paragraphs 3.9. of Appendix 2 to this Annex**Test report number: RDW-19160126-02**

Base part: ID4- 19160126

Suffix: 02

1. General

1.1. Axle manufacturer (name and address) : BPW Bergische Achsen KG
Ohlerhammer
D-51674 Wiehl

1.1.1. Make of axle manufacturer : BPW

1.2. Brake manufacturer (name and address) : See 1.1.

1.2.1. Brake identifier : ID2- SN4220.

1.2.2. Automatic brake adjustment device : ~~integrated~~/non-integrated⁽¹⁾

1.3. Manufacturer's Information Document : See item 6

A.2. Test Record

The following data has to be recorded for each test:

A.2.1. Test code (see paragraph 3.9.2. of
Appendix 2 of this annex) : GA140522A.2.2. Test specimen: (precise identification of the variant tested related to the Manufacturer's
Information Document. See also paragraph 3.9.2. of Appendix 2 of this annex)

...



Test report number: RDW-19160126-02

A.2.2.1.	Axle	
A.2.2.1.1.	Axle identifier	: ID1-H 142
A.2.2.1.2.	Identification of tested axle	: 30.14.744.357
A.2.2.1.3.	Test axle load (F_e identifier)	: ID3-13930 daN
A.2.2.2.	Brake	
A.2.2.2.1.	Brake identifier	: ID2-SN4220
A.2.2.2.2.	Identification of tested brake	: 03.109.77.46.0
A.2.2.2.3.	Maximum stroke capability of the brake ⁽²⁾	: -
A.2.2.2.4.	Effective length of the cam shaft ⁽³⁾	: 706 (mm)
A.2.2.2.5.	Material variation as per paragraph 3.8 (m) of Appendix 2 of this annex	: N.A.
A.2.2.2.6.	Brake drum/disc ⁽¹⁾	
A.2.2.2.6.1.	Actual test mass of disc/drum ⁽¹⁾	: 61,8 kg
A.2.2.2.6.2.	Nominal external diameter of disc ⁽²⁾	: N.A.
A.2.2.2.6.3.	Type of cooling of the disc ventilated/ non-ventilated ⁽¹⁾	: N.A.
A.2.2.2.6.4.	With or without integrated hub ⁽¹⁾	: N.A.
A.2.2.2.6.5.	Disc with integrated drum - with or without parking brake function ^{(1) (2)}	: N.A.
A.2.2.2.6.6.	Geometric relationship between disc friction surfaces and disc mounting	: N.A.
A.2.2.2.6.7.	Base material	: Grey Cast Iron
A.2.2.2.7.	Brake lining or pad ⁽¹⁾	
A.2.2.2.7.1.	Manufacturer	: TMD Friction , Leverkusen
A.2.2.2.7.2.	Make	: Textar
A.2.2.2.7.3.	Type	: T090
A.2.2.2.7.4.	Method of attachment of the lining/pad on the brake shoe/back plate ⁽¹⁾	: Riveted



Test report number: RDW-19160126-02

- A.2.2.2.7.5. Thickness of back plate, weight of shoes or other describing information (Manufacturer's Information Document)⁽¹⁾ : See ID
- A.2.2.2.7.6. Base material of brake shoe/back plate⁽¹⁾ : Steel
- A.2.2.3. Automatic brake adjustment device (not applicable in the case of integrated automatic brake adjustment device)⁽¹⁾
- A.2.2.3.1. Manufacturer (name and address) : See 1.1.
- A.2.2.3.2. Make : BPW
- A.2.2.3.3. Type : AGS
- A.2.2.3.4. Version : 2
- A.2.2.4. Wheel(s) (dimensions see Figures 1A and 1B in Appendix 5 of this annex)
- A.2.2.4.1. Reference tyre rolling radius (R_e) at test axle load (F_e) : 543 (mm)
- A.2.2.4.2. Data of the fitted wheel during testing:
- | Tyre size | Rim size | X_e (mm) | D_e (mm) | E_e (mm) | G_e (mm) |
|-----------|-------------|------------|------------|------------|------------|
| 13R22,5 | 22,5 x 9.00 | 297 | 571,0 | Min 16 | Min -18 |
- A.2.2.5. Lever length l_e : 165 (mm)
- A.2.2.6. Brake actuator
- A.2.2.6.1. Manufacturer : Wabco Fahrzeug systeme GmbH
- A.2.2.6.2. Make : WABCO
- A.2.2.6.3. Type : 423.008.919.0 (36")
(2306*p-791)
- A.2.2.6.4. (Test) identification number : BC 0031.0



Test report number: RDW-19160126-02

A.2.3. Test results (corrected to take account of rolling resistance of 0.01 - F_e)

A.2.3.2. In the case of vehicles of categories O₃ and O₄ where the O₃ trailer has been subject to the Type-III test:

Test type:		0	III	
Annex 11, Appendix 2, paragraph:		3.5.1.2.	3.5.3.1.	3.5.3.2.
Test speed initial	km/h	60	60	60
Test speed final	km/h	0	30	0
Brake actuator pressure p_e	kPa	641	-	642
Number of brake applications	-	-	20	-
Duration of braking cycle	-	-	60	-
Brake force developed T_e	N	<u>75468</u>	<u>42998</u>	<u>61600</u>
Brake efficiency T_e/F_e	-	<u>0.54</u>	<u>0.31</u>	<u>0.44</u>
Actuator stroke s_e	mm	54,5	-	61,4
Brake input torque C_e	Nm	<u>2308</u>	-	<u>2312</u>
Brake input threshold torque $C_{0,e}$	Nm	50	-	50



Test report number: RDW-19160126-02

B.2. Test Record

The following data has to be recorded for each test:

- B.2.1. Test code (see paragraph 3.9.2. of Appendix 2 of this annex) : AA160707
- B.2.2. Test specimen: (precise identification of the variant tested related to the Manufacturer's Information Document. See also paragraph 3.9.2. of Appendix 2 of this annex)
...
- B.2.2.1. Axle
- B.2.2.1.1. Axle identifier : ID1-H 142
- B.2.2.1.2. Identification of tested axle : 30.14.744.357
- B.2.2.1.3. Test axle load (F_e identifier) : ID3-13930 daN
- B.2.2.2. Brake
- B.2.2.2.1. Brake identifier : ID2-SN4220
- B.2.2.2.2. Identification of tested brake : 03.109.77.46.0
- B.2.2.2.3. Maximum stroke capability of the brake ⁽²⁾ : -
- B.2.2.2.4. Effective length of the cam shaft ⁽³⁾ : 286 (mm)
- B.2.2.2.5. Material variation as per paragraph 3.8 (m) of Appendix 2 of this annex : N.A.
- B.2.2.2.6. Brake drum/disc ⁽¹⁾
- B.2.2.2.6.1. Actual test mass of disc/drum ⁽¹⁾ : 61,8 kg
- B.2.2.2.6.2. Nominal external diameter of disc ⁽²⁾ : N.A.
- B.2.2.2.6.3. Type of cooling of the disc ventilated/non-ventilated ⁽¹⁾ : N.A.
- B.2.2.2.6.4. With or without integrated hub ⁽¹⁾ : N.A.
- B.2.2.2.6.5. Disc with integrated drum - with or without parking brake function ⁽¹⁾⁽²⁾ : N.A.
- B.2.2.2.6.6. Geometric relationship between disc friction surfaces and disc mounting : N.A.
- B.2.2.2.6.7. Base material : Grey Cast Iron
- B.2.2.2.7. Brake lining or pad ⁽¹⁾
- B.2.2.2.7.1. Manufacturer : TMD Friction , Leverkusen



Test report number: RDW-19160126-02

- B.2.2.2.2. Make : Textar
- B.2.2.2.3. Type : T090
- B.2.2.2.4. Method of attachment of the lining/pad on the brake shoe/~~back plate~~⁽¹⁾ : Riveted
- B.2.2.2.5. Thickness of back plate, weight of shoes or other describing information (Manufacturer's Information Document)⁽¹⁾ : See ID
- B.2.2.2.6. Base material of brake shoe/back plate⁽¹⁾ : Steel
- B.2.2.3. Automatic brake adjustment device (not applicable in the case of integrated automatic brake adjustment device)⁽¹⁾
- B.2.2.3.1. Manufacturer (name and address) : See 1.1.
- B.2.2.3.2. Make : BPW
- B.2.2.3.3. Type : AGS
- B.2.2.3.4. Version : 0
- B.2.2.4. Wheel(s) (dimensions see Figures 1A and 1B in Appendix 5 of this annex)
- B.2.2.4.1. Reference tyre rolling radius (R_e) at test axle load (F_e) : 543 (mm)
- B.2.2.4.2. Data of the fitted wheel during testing:
- | Tyre size | Rim size | X_e (mm) | D_e (mm) | E_e (mm) | G_e (mm) |
|-----------|-------------|------------|------------|------------|------------|
| 13R22,5 | 22,5 x 9.00 | 297 | 571,0 | Min 16 | Min -18 |
- B.2.2.5. Lever length l_e : 165 (mm)
- B.2.2.6. Brake actuator
- B.2.2.6.1. Manufacturer : Wabco Fahrzeug systeme GmbH
- B.2.2.6.2. Make : WABCO
- B.2.2.6.3. Type : 423.008.919.0 (36")
(2306*p-791)
- B.2.2.6.4. (Test) identification number : BC 0031.0



Test report number: RDW-19160126-02

B.2.3. Test results (corrected to take account of rolling resistance of 0.01 - F_e)

B.2.3.2. In the case of vehicles of categories O₃ and O₄ where the O₃ trailer has been subject to the Type-III test:

Test type:		0	III	
Annex 11, Appendix 2, paragraph:		3.5.1.2.	3.5.3.1.	3.5.3.2.
Test speed initial	km/h	60	60	60
Test speed final	km/h	0	30	0
Brake actuator pressure p_e	kPa	619	-	620
Number of brake applications	-	-	20	-
Duration of braking cycle	-	-	60	-
Brake force developed T_e	N	<u>78592</u>	<u>42146</u>	<u>63162</u>
Brake efficiency T_e/F_e	-	<u>0.56</u>	<u>0.30</u>	<u>0.45</u>
Actuator stroke s_e	mm	29,5	-	50,5
Brake input torque C_e	Nm	2224	-	2228
Brake input threshold torque $C_{o,e}$	Nm	50	-	50



Test report number: RDW-19160126-02

C.2. Test Record

The following data has to be recorded for each test:

- C.2.1. Test code (see paragraph 3.9.2. of Appendix 2 of this annex) : AA250121
- C.2.2. Test specimen: (precise identification of the variant tested related to the Manufacturer's Information Document. See also paragraph 3.9.2. of Appendix 2 of this annex)
...
- C.2.2.1. Axle
- C.2.2.1.1. Axle identifier : ID1-H 142
- C.2.2.1.2. Identification of tested axle : 30.14.744.357
- C.2.2.1.3. Test axle load (F_e identifier) : ID3-13930 daN
- C.2.2.2. Brake
- C.2.2.2.1. Brake identifier : ID2-SN4220
- C.2.2.2.2. Identification of tested brake : 03.109.77.46.0
- C.2.2.2.3. Maximum stroke capability of the brake⁽²⁾ : -
- C.2.2.2.4. Effective length of the cam shaft⁽³⁾ : 706 (mm)
- C.2.2.2.5. Material variation as per paragraph 3.8 (m) of Appendix 2 of this annex : N.A.
- C.2.2.2.6. Brake drum/disc⁽¹⁾
- C.2.2.2.6.1. Actual test mass of disc/drum⁽¹⁾ : 61,69 kg
- C.2.2.2.6.2. Nominal external diameter of disc⁽²⁾ : N.A.
- C.2.2.2.6.3. Type of cooling of the disc ventilated/non-ventilated⁽¹⁾ : N.A.
- C.2.2.2.6.4. With or without integrated hub⁽¹⁾ : N.A.
- C.2.2.2.6.5. Disc with integrated drum - with or without parking brake function⁽¹⁾⁽²⁾ : N.A.
- C.2.2.2.6.6. Geometric relationship between disc friction surfaces and disc mounting : N.A.
- C.2.2.2.6.7. Base material : Grey Cast Iron



Test report number: RDW-19160126-02

C.2.2.2.7. Brake lining or pad ⁽¹⁾

C.2.2.2.7.1. Manufacturer : Frasle S.A.

C.2.2.2.7.2. Make : BPW

C.2.2.2.7.3. Type : 6404

C.2.2.2.7.4. Method of attachment of the lining/pad on the brake shoe/back plate ⁽¹⁾ : Riveted

C.2.2.2.7.5. Thickness of back plate, weight of shoes or other describing information (Manufacturer's Information Document) ⁽¹⁾ : See ID

C.2.2.2.7.6. Base material of brake shoe/back plate ⁽¹⁾ : Steel

C.2.2.3. Automatic brake adjustment device (not applicable in the case of integrated automatic brake adjustment device) ⁽¹⁾

C.2.2.3.1. Manufacturer (name and address) : See 1.1.

C.2.2.3.2. Make : BPW

C.2.2.3.3. Type : AGS

C.2.2.3.4. Version : 2

C.2.2.4. Wheel(s) (dimensions see Figures 1A and 1B in Appendix 5 of this annex)

C.2.2.4.1. Reference tyre rolling radius (R_e) at test axle load (F_e) : 543 (mm)

C.2.2.4.2. Data of the fitted wheel during testing:

Tyre size	Rim size	X_e (mm)	D_e (mm)	E_e (mm)	G_e (mm)
13R22,5	22,5 x 9.00	297	571,0	Min 16	Min -18

C.2.2.5. Lever length l_e : 165 (mm)

C.2.2.6. Brake actuator

C.2.2.6.1. Manufacturer : See 1.1.

C.2.2.6.2. Make : BPW

C.2.2.6.3. Type : 05.444.17 (36")
(2362*p-365)

C.2.2.6.4. (Test) identification number : (BC 0069.1)



Test report number: RDW-19160126-02

C.2.3. Test results (corrected to take account of rolling resistance of 0.01 - F_e)

C.2.3.2. In the case of vehicles of categories O₃ and O₄ where the O₃ trailer has been subject to the Type-III test:

Test type:		0	III	
Annex 11, Appendix 2, paragraph:		3.5.1.2.	3.5.3.1.	3.5.3.2.
Test speed initial	km/h	60	60	60
Test speed final	km/h	0	30	0
Brake actuator pressure p_e	kPa	657	-	657
Number of brake applications	-	-	20	-
Duration of braking cycle	-	-	60	-
Brake force developed T_e	N	79349	42004	63161
Brake efficiency T_e/F_e	-	0,57	0,30	0,45
Actuator stroke s_e	mm	43	50,7-43,4	52
Brake input torque C_e	Nm	2500	-	2500
Brake input threshold torque $C_{o,e}$	Nm	50	-	50



Test report number: RDW-19160126-02

D.2. Test Record

The following data has to be recorded for each test:

- D.2.1. Test code (see paragraph 3.9.2. of Appendix 2 of this annex) : AA231031
- D.2.2. Test specimen: (precise identification of the variant tested related to the Manufacturer's Information Document. See also paragraph 3.9.2. of Appendix 2 of this annex)
...
- D.2.2.1. Axle
- D.2.2.1.1. Axle identifier : ID1-H 142
- D.2.2.1.2. Identification of tested axle : 30.14.744.357
- D.2.2.1.3. Test axle load (F_e identifier) : ID3-13930 daN
- D.2.2.2. Brake
- D.2.2.2.1. Brake identifier : ID2-SN4220
- D.2.2.2.2. Identification of tested brake : 03.109.77.46.0
- D.2.2.2.3. Maximum stroke capability of the brake ⁽²⁾ : -
- D.2.2.2.4. Effective length of the cam shaft ⁽³⁾ : 286 (mm)
- D.2.2.2.5. Material variation as per paragraph 3.8 (m) of Appendix 2 of this annex : N.A.
- D.2.2.2.6. Brake drum/~~disc~~ ⁽¹⁾
- D.2.2.2.6.1. Actual test mass of ~~disc~~/drum ⁽¹⁾ : 61,69 kg
- D.2.2.2.6.2. Nominal external diameter of disc ⁽²⁾ : N.A.
- D.2.2.2.6.3. Type of cooling of the disc ventilated/
non-ventilated ⁽¹⁾ : N.A.
- D.2.2.2.6.4. With or without integrated hub ⁽¹⁾ : N.A.
- D.2.2.2.6.5. Disc with integrated drum - with or
without parking brake function ⁽¹⁾⁽²⁾ : N.A.
- D.2.2.2.6.6. Geometric relationship between disc
friction surfaces and disc mounting : N.A.
- D.2.2.2.6.7. Base material : Grey Cast Iron



Test report number: RDW-19160126-02

D.2.2.2.7. Brake lining or pad ⁽¹⁾

D.2.2.2.7.1. Manufacturer : Frasle S.A.

D.2.2.2.7.2. Make : BPW

D.2.2.2.7.3. Type : 6404

D.2.2.2.7.4. Method of attachment of the lining/pad on the brake shoe/back plate ⁽¹⁾ : Riveted

D.2.2.2.7.5. Thickness of back plate, weight of shoes or other describing information (Manufacturer's Information Document) ⁽¹⁾ : See ID

D.2.2.2.7.6. Base material of brake shoe/back plate ⁽¹⁾ : Steel

D.2.2.3. Automatic brake adjustment device (not applicable in the case of integrated automatic brake adjustment device) ⁽¹⁾

D.2.2.3.1. Manufacturer (name and address) : See 1.1.

D.2.2.3.2. Make : BPW

D.2.2.3.3. Type : AGS

D.2.2.3.4. Version : 0

D.2.2.4. Wheel(s) (dimensions see Figures 1A and 1B in Appendix 5 of this annex)

D.2.2.4.1. Reference tyre rolling radius (R_e) at test axle load (F_e) : 543 (mm)

C.2.2.4.2. Data of the fitted wheel during testing:

Tyre size	Rim size	X_e (mm)	D_e (mm)	E_e (mm)	G_e (mm)
13R22,5	22,5 x 9.00	297	571,0	Min 16	Min -18

D.2.2.5. Lever length l_e : 165 (mm)

D.2.2.6. Brake actuator

D.2.2.6.1. Manufacturer : See 1.1.

D.2.2.6.2. Make : BPW

D.2.2.6.3. Type : 05.444.17 (36")
(2362*p-365)

D.2.2.6.4. (Test) identification number : (BC 0069.1)



Test report number: RDW-19160126-02

D.2.3. Test results (corrected to take account of rolling resistance of 0.01 - F_e)

D.2.3.2. In the case of vehicles of categories O₃ and O₄ where the O₃ trailer has been subject to the Type-III test:

Test type:		0	III	
Annex 11, Appendix 2, paragraph:		3.5.1.2.	3.5.3.1.	3.5.3.2.
Test speed initial	km/h	60	60	60
Test speed final	km/h	0	30	0
Brake actuator pressure p_e	kPa	650	-	650
Number of brake applications	-	-	20	-
Duration of braking cycle	-	-	60	-
Brake force developed T_e	N	83467	42430	65576
Brake efficiency T_e/F_e	-	0,60	0,30	0,47
Actuator stroke s_e	mm	50,5	47,3-38,2	51,9
Brake input torque C_e	Nm	2533	-	2533
Brake input threshold torque $C_{o,e}$	Nm	50	-	50



Test report number: RDW-19160126-02

2.3.3. This item is to be completed only when the brake has been subject to the test procedure defined in paragraph 4. of Annex 19 – Part 1 to this Regulation to verify the cold performance characteristics of the brake by means of the brake factor (B_F).

2.3.3.1. Brake factor (B_F) : 9

2.3.3.2. Declared threshold torque $C_{0,dec}$: 50 Nm

2.3.4. Performance of the automatic adjustment device (if applicable)

2.3.4.1. Free running according to paragraph 3.6.3. of Annex 11, Appendix 2 : yes/~~no~~⁽¹⁾

3. Application range

This application range specifies the axle/brake variants that are covered in this test report, by showing which variables are covered by the individual test codes.

4. This test has been carried out and the results reported in accordance with Appendix 2 to Annex 11 and where appropriate paragraph 4. of Annex 19 – Part 1 to Regulation number 13 as last amended by the 13 series of amendments.

At the end of the test defined in paragraph 3.6. of Annex 11, Appendix 2⁽⁴⁾ the requirements of paragraph 5.2.2.8.1. of Regulation number 13 were deemed to be fulfilled/~~not fulfilled~~⁽¹⁾



Technical Service⁽⁵⁾ carrying out the test : RDW
P.O. Box 777
2700 AT Zoetermeer
The Netherlands

Signed :

W.R. Hartman

Date : 5 March 2025

Type Approval Authority⁽⁵⁾ : RDW
P.O. Box 777
2700 AT Zoetermeer
The Netherlands

Signed :

B. P. Loen

Date : 5 March 2025

⁽¹⁾ Strike out what does not apply.

⁽²⁾ Applies to disc brakes only.

⁽³⁾ Applies to drum brakes only.

⁽²⁾ Applies to disc brakes only.

⁽³⁾ Applies to drum brakes only.

⁽²⁾ Applies to disc brakes only.

⁽³⁾ Applies to drum brakes only.

⁽²⁾ Applies to disc brakes only.

⁽³⁾ Applies to drum brakes only.

⁽⁴⁾ Only to be completed when an automatic brake wear adjustment device is installed.

⁽⁵⁾ To be signed by different persons even when the Technical Service and Type Approval Authority are the same or alternatively, a separate Type Approval Authority authorization is issued with the report.

Information Document BPW -SN4220.00

TRAILER AXLE AND BRAKE INFORMATION DOCUMENT WITH RESPECT TO THE ALTERNATIVE TYPE I AND TYPE III PROCEDURE

(according to ECE R 13, Annex 11 – Appendix 5)

Date	Revision	Position	Amendment of terms
10.06.2014	0		
01.07.2016	1	3.2.1.	Add Type AGS 0
11.02.2025	2	3.2.1. & 3.4.2	Add Brake lining BPW 6404 Editorial corrections.

1. GENERAL

1.1. Name and address of axle or vehicle manufacturer:

BPW Bergische Achsen KG
Ohlerhammer
D-51674 Wiehl

2. AXLE DATA

- 2.1. Manufacturer (name and address) see 1.1.
 2.2. Type/variant H
 2.3. Axle identifier ID1- H142
 2.4. Test axle load (F_e) ID3- 13930
 2.5. Wheel and brake data according to the following figure 1A:

FIGURE 1A

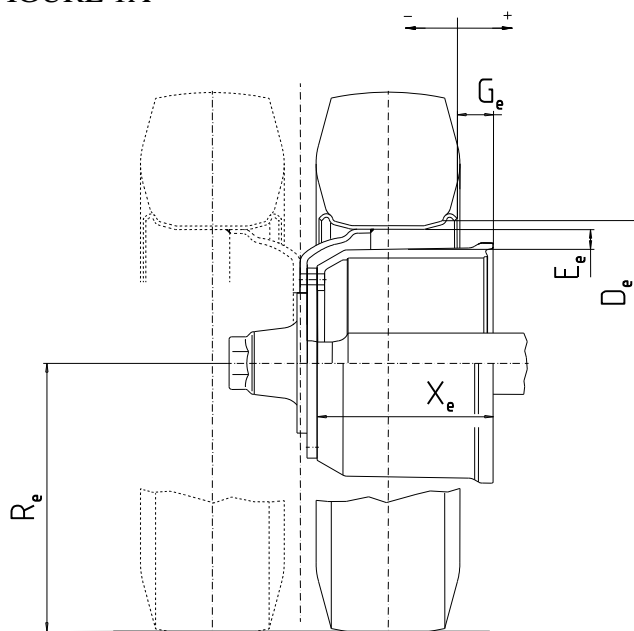

Permitted range:

D (mm)	E (mm)	G (mm)	R (mm)
min. 571,5	min. 16	min. -18	min. 0,8 * 543

- 3. BRAKE
- 3.1. General information
- 3.1.1. MakeBPW
- 3.1.2. Manufacturer (name and address) see 1.1.
- 3.1.3. Type of brake (e.g. drum / disc) Drum Brake
- 3.1.3.1. Variant (e.g. S-cam, single wedge etc.) S-cam brake
- 3.1.4. Brake identifier ID2- SN4220
- 3.1.5. Brake data according to the following figure 2A:

FIGURE 2A

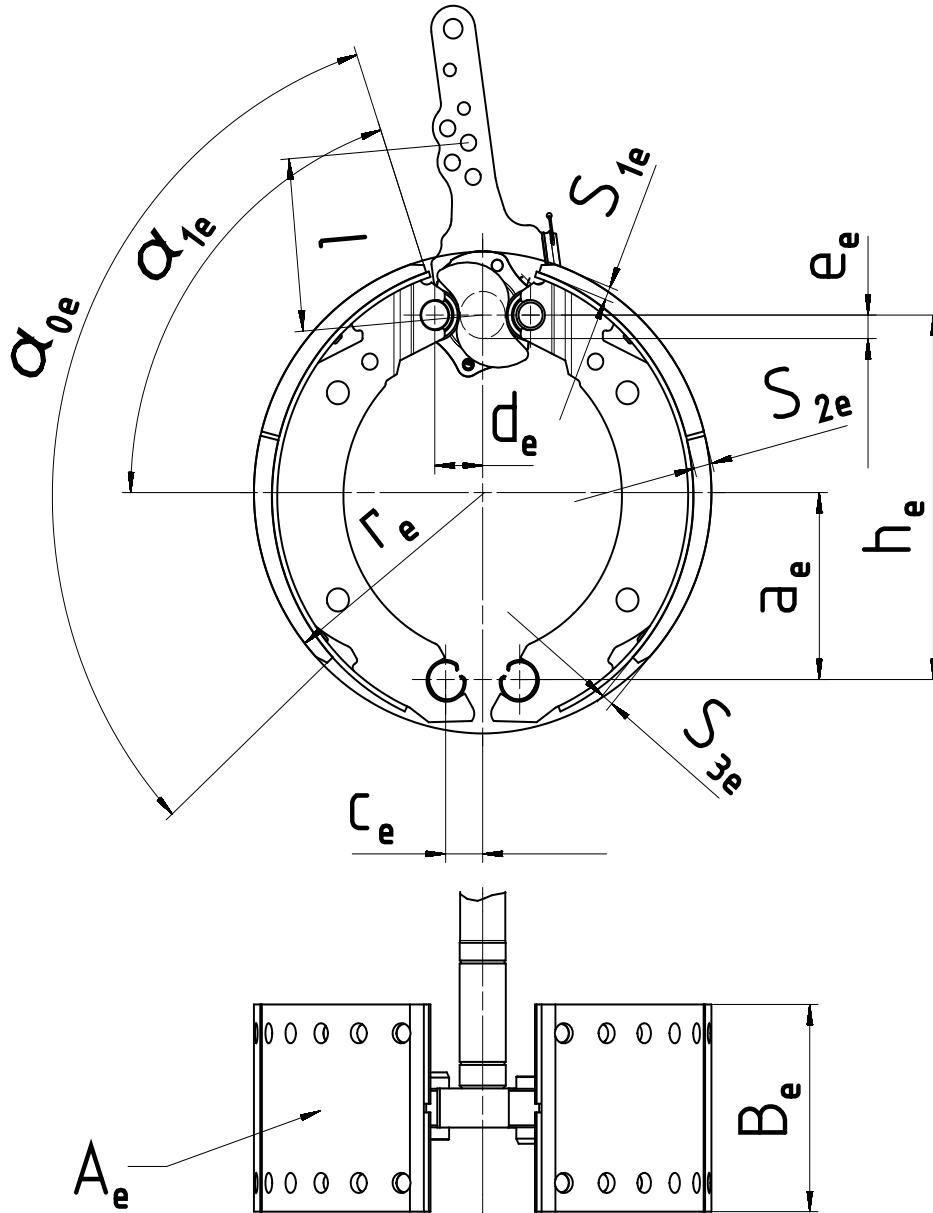

a_e (mm)	h_e (mm)	c_e (mm)	d_e (mm)	e_e (mm)	α_{0e} (°)	α_{1e} (°)	B_e (mm)	r_e (mm)	A_e (cm ²)	S_{1e} (mm)	S_{2e} (mm)	S_{3e} (mm)
163,7	317,7	33	43,5	14	114	70,5	200	210	1554	13	18	13

- 3.1.6. Brake factor B_F 9,0

3.2. Drum brake data

3.2.1. Brake adjustment device (external/integrated) external

3.2.1.1. Alternative	3.2.1.2. Manufacturer and address	3.2.1.3. Make	3.2.1.4. Type	3.2.1.5. Version	3.2.1.6. Effective length of the cam shaft	3.2.1.7 Brake Lining	3.2.1.8 Test code
A	see 1.1.	BPW	AGS-	2	max. 706 mm	Textar T090	GA140522
B	see 1.1	BPW	AGS-	0	max. 286 mm	Textar T090	AA160707
<u>C</u>	<u>see 1.1</u>	<u>BPW</u>	<u>AGS-</u>	<u>2</u>	<u>max. 706 mm</u>	<u>BPW</u> <u>6404</u>	<u>AA250121</u>
<u>D</u>	<u>see 1.1</u>	<u>BPW</u>	<u>AGS-</u>	<u>0</u>	<u>max. 286 mm</u>	<u>BPW</u> <u>6404</u>	<u>AA231031</u>

- 3.2.2. Declared maximum brake input torque C_{max} 2800 Nm
for calculation (pm= 650 kPa) 2250 Nm
In case of camshaft with gearing A42x38 DIN 5482:
Declared maximum brake input torque C_{max} 3700 Nm
for calculation (pm= 650 kPa) 3000 Nm
- 3.2.3. Mechanical efficiency $\eta =$ 0,8
- 3.2.4. Declared brake input threshold torque $C_{0,dec}$ 50 Nm
- 3.2.5. Effective length of the cam shaft see 3.2.1.6.

3.3. Brake drum

3.3.1. Max diameter of friction surface (wear limit)	3.3.2. Base material	3.3.3. Declared mass	3.3.4. Nominal mass	3.3.5. Brake drum	3.3.6. Identification Code
425,5 mm	cast iron	56 kg	60 kg	without hub	BPW 03.10x.xx.xx.x*

3.4. Brake lining

3.4.1 Brake lining data TMD Friction

- 3.4.1.1 Manufacturer and address TMD Friction, Leverkusen
- 3.4.1.2 Make Textar
- 3.4.1.3 Type T 090
- 3.4.1.4 Identification (type identification on lining) Textar T 090
- 3.4.1.5 Minimum thickness (wear limit) 5 mm
- 3.4.1.6 Method of attaching friction material to brake shoe riveted
- 3.4.1.6.1 Worst case of attachment (in the case of more than one)..... not applicable
- 3.4.1.6.2 Range of the weight of one brake shoe (without linings and rollers)..... min. 6,2 kg
- 3.4.1.6.3 Base material of the brake shoes: steel

* The different numbers characterized in this information document with "x" are representing versions of the drum, whose modifications have however no influence on the function and effect regarding the tests carried out in accordance to ECE-Regulation No. 13 and are not part of the identification code.

3.4.2	Brake lining data Frasle	
3.4.2.1	Manufacturer and address	Frasle S.A., Caxias do Sul-RS/Brazil
3.4.2.2	Make	BPW
3.4.2.3	Type	6404
3.4.2.4	Identification (type identification on lining)	BPW 6404
3.4.2.5	Minimum thickness (wear limit)	5 mm
3.4.2.6	Method of attaching friction material to brake shoe	riveted
3.4.2.6.1	Worst case of attachment (in the case of more than one).....	not applicable
3.4.2.6.2	Range of the weight of one brake shoe (without linings and rollers).....	min. 6,2 kg
3.4.2.6.3	Base material of the brake shoes:	steel